

Datasheet

RM024 – RAMP Wireless Module

2.4 GHz FHSS Wireless Module

Version 4.2

REVISION HISTORY

Ver	Date	Notes	Contributor(s)	Approver
1.0		Initial Release		Chris Downey
2.1		Added firmware changes, updated the name of the Force 9600 Pin, removed old references to LT2510 part numbers, added new information on cyclic sleep and Antenna Switch Override. Added a table under Max Power and a table for the Set Max Power command		Chris Downey
2.2		Minor grammatical fixes.		Chris Downey
2.3	27 June 2013	PWM output data was corrected to a 39.3846 µS period vs. 315.077, as was stated previously.		Chris Downey
2.4	12 July 2013	Minor edits, removed Firmware History and references irrelevant to RM024.		Chris Downey
2.5	10 Oct 2013	Corrected Antenna Select Override information error. Changed 0x59 to 0x5B		Chris Downey
3.0	10 Dec 2013	Separated Hardware Integration Guide (HIG) from User Guide information (created two separate documents). Add Related Documents section.		Sue White
3.1	10 Jan 2014	Added 10 mW version information.		Chris Downey
3.2	05 Mar 2015	Added section on Reflow Parameters.		Chris Downey
3.3	22 Jan 2016	Update product numbers. Updated antenna information. Converted to new template. General edits.		N. Zach Hogya
3.4	24 Feb 2016	Updates to antenna information.		Daniel Waters
3.5	10 Aug 2016	Changed from <i>HIG</i> to <i>Datasheet</i> Updated Receiver Sensitivity numbers		Zach Hogya
3.6	26 June 2017	Updated EU DoC for new RED standards		Tom Smith
3.7	28 July 2017	Added RM024-P10-C-30 to the DoC product list		Jonathan Kaye
3.8	3 Nov 2017	Added Note 6		Jonathan Kaye
3.9	01 Feb 2018	Added MIC information		Maggie Teng
3.10	14 Feb 2019	Updated template, logos, and URLs		Sue White
3.11	23 Sept 2019	Updated antenna information		Jonathan Kaye
3.12	30 June 2020	Added PMN to title page; added IC statement; added FlexPIFA antenna to FCC and IC antenna tables		Maggie Teng
4.0	15 Dec 2020	Updated all regulatory information	Maggie Teng Ryan Urness	Jonathan Kaye
4.1	05 Feb 2021	Updated EN 300 328 standard version	Ryan Urness	Jonathan Kaye
4.2	21 Feb 2021	Transferred all detailed regulatory information to separate document	Sue White	Jonathan Kaye

CONTENTS

1	RAMP Modules.....	4
1.1	Key Features.....	4
1.2	Detailed Specification.....	5
1.3	Pin Definitions.....	6
1.4	Input Characteristics.....	8
1.5	Output Characteristics.....	8
1.6	Block Diagram.....	8
1.7	Timing Specifications.....	9
1.8	RF Hop Frame.....	9
2	Hardware Interface.....	10
2.1	Pin Descriptions.....	10
3	Mechanical Considerations.....	12
4	Reflow Parameters.....	15
5	Ordering Information.....	16
6	Regulatory Information.....	16
7	Related Documents and Files.....	17
8	Additional Assistance.....	17

1 RAMP MODULES

Laird Connectivity RAMP (Range Amplified MultiPoint) modules are designed to provide robust wireless communications for any number of applications requiring a wireless transport for serial data. RAMP modules feature a Frequency Hopping Spread Spectrum (FHSS) protocol for excellent interference and multipath immunity. RAMP modules server/client architecture allows for more than 16 million clients to be addressed and communicating within the network.

The RM024 RAMP module improves upon Laird Connectivity's 2.4 GHz RAMP predecessors by lowering power consumption through the use of three different sleep mode options, an improved link budget, the ability for close proximity operation at low power, and the inclusion of a switchable antenna output (RM024-xxxx-M-yy versions only).

The RM024 is available in two versions:

- **RM024-S125-x-xx/RM024-P125-x-xx** – Contains 125 mW maximum conducted output power which is approved for North American and similar markets.
- **RM024-S10-x-xx/RM024-P10-x-xx** – Contains 10 mW maximum conducted output power which is approved for European and similar markets.

These modules are identical except for output power, transmit power consumption, and the number of RF channels available. Differences between the two versions, where applicable, are denoted based on part number.

This document contains information about the hardware and software interface between a Laird Connectivity RM024 transceiver and an OEM host. Information includes the theory of operation, specifications, interface definitions, and mechanical drawings.

Note: Unless mentioned specifically by name, the RM024 modules are referred to as *module*, *radio*, or *transceiver*. Individual naming is used to differentiate product specific features. The host (PC/microcontroller/any device to which the RM024 module is connected) is referred to as *OEM host* or *host*.

1.1 Key Features

- Retries and acknowledgements
- Configurable network parameters
- Multiple generic I/O
- 280 kbps or 500 kbps RF data stream
- Idle current draw of 9.5 mA, sleep current of <1 uA (varies depending on sleep mode)
- Software-selectable interface baud ranging from 1200 bps to 230.4 kbps
- Upgradable FW through serial port
- Low cost, low power, and small size ideal for high volume, portable, and battery powered applications
- All modules are qualified for Industrial temperatures (-40°C to 85°C)
- Advanced configuration available using Laird Connectivity's Command Interface
- Easy-to-use Laird Connectivity Configuration and Test Utility software
- Switchable antenna output, either integrated antenna or external antenna through U.FL (RM024-S125-M, RM024-P125-M, RM024-S10-M, and RM024-P10-M radios only)

1.2 Detailed Specification

Table 1: Specifications table

General			
Form Factor	SMD-ANT+U.FL, Pluggable-ANT+U.FL, SMD-U.FL, Pluggable-U.FL		
Antenna	Dual antenna with integrated antenna and U.FL or External antenna through U.FL connector		
Serial Interface Data Rate	Baud rates from 1200 to 230400. Non-standard baud rates are also supported.		
Channels	125 mW – 42 or 78 selectable channels 10 mW – 42 selectable channels		
Security	Channelization, System ID, Vendor ID, and Extended System ID		
Minimum Flash (EEPROM) Memory Endurance	1000 Write/Erase cycles		
Transceiver			
Frequency Band	2400-2483.5 MHz		
RF Data Rate (Raw)	280 kbps or 500 kbps selectable		
Hop Bin Spacing	900 kHz over 79 hops 1500 kHz over 43 hops		
RF Technology	Frequency Hopping Spread Spectrum		
Modulation	MSK		
Maximum Output Power Conducted ¹	FCC – +5 to +21 dBm (selectable) EU – +3.5 to +10 dBm (not selectable)		
Supply Voltage	2.3-3.6 V ± 50 mV ripple		
Current Draw	RM024 Version	125 mW	10 mW
	Tx Burst	136 mA	40 mA
	Rx Active	36 mA	36 mA
	Idle Current	9.5 mA	9.5 mA
	PM2/Cyclic Sleep	0.9 µA	0.9 µA
	PM3/Deep Sleep	0.38 µA	0.38 µA
Receiver Sensitivity (1% PER)	RF Profile	Receiver Sensitivity (dBm) (1% PER)	
	500 kbps	-88	
	280 kbps	-92	
	FEC 500 kbps	-91 (See Note 5)	
	FEC 280 kbps	-95 (See Note 5)	
*See Note 6			
Range (based on external 2.0 dBi antenna at 280 kbps RF data rate) ²		Outdoor (line-of-sight)	Indoor (estimated)
	125 mW	4 km (2.5 miles)	400 m (1300 feet)
10 mW	1.0 km (0.6 miles)	100 m (328 feet)	
Environmental			
Temperature (Operational)	-40 °C to 85 °C		
Temperature (Storage)	-50 °C to 150 °C		

Physical	
SMD-Multi Antenna Dimensions	25.4 mm x 39 mm x 3.6 mm (1.0" x 1.54" x 0.14")
SMD-U.FL Dimensions	25.4 mm x 32.4 mm x 3.6 mm (1.0" x 1.28" x 0.14")
Pluggable-Multi Antenna Dimensions	26.7 mm x 39.6 mm x 11.3 mm (1.05" x 1.56" x 0.44")
Pluggable-U.FL Dimensions	26.7 mm x 33 mm x 10.6 mm (1.05" x 1.29" x 0.42")

Certifications	
FCC – Part 15.247	KQL-RM024
ISED (Canada)	2268C-RM024
EU	Yes – RM024-x10-x versions
RoHS	Yes
Brazil (Anatel) ⁴	None
AS/NZS	Yes

Notes:

1. Maximum output stated, step measurements for power could vary by +/- 2.0 dBm.
2. Range distances are estimates and vary with the installation environment. Measurements were taken at 4.1 miles with a 5 dBi antenna for FCC modules.
3. See [Regulatory Information](#) in this guide.
4. Contact your sales representative for more details.
5. While the use of FEC does not affect the actual PER, it does allow correct reception at a lower SNR, thus extending communication range. We've measured this to yield an effective sensitivity increase on the order of 3dBm.
6. The RM024 can operate at two different RF baud rates: 250 kbps and 500 kbps. The chip receiver saturation is -11dBm at 250 kbps and -15 dBm at 500 kbps. Inside the module, there is an FEM which has net gain of about 11-13dB. For 500 kbps RF baud rate, the input RF signal must be less than -28 dBm without causing any saturation, and at 250 kbps RF baud rate the signal must be less than -24dbm. In real deployment, some margin to cover the signal variation is required. With all these factors considered, we suggest the received RF signal should not be stronger than -40 dBm.

1.3 Pin Definitions

Table 2: RM024 pins

SMT Pin	Pluggable Pin	Type	Signal Name	Functions
1	7	O	GIO-0	Generic Output / Hop_Frame
2	6	O	GIO_1	Generic Output
3	8		DNC	Do Not Connect
4	17	O	GIO_2	RS485 Driver Enable
5	19	O	GIO_3	PWM Output
6	3	I	RXD	Asynchronous serial data input to transceiver
7	2	O	TXD	Asynchronous serial data output from transceiver
8	10	GND	GND	Signal Ground
9	1	PWR	V _{CC}	2.3 – 3.6 V ±50 mV ripple (must be connected)
10	-	PWR	V _{pa}	2.3 - 3.6 V ±50 mV ripple (must be connected on SMT version)

SMT Pin	Pluggable Pin	Type	Signal Name	Functions
11	-	GND	GND	Signal Ground
12	9	I	$\overline{\text{Force 9600}}$ /Sleep Interrupt	<p>Force 9600 – When pulled logic Low and then applying power or resetting, the transceiver’s serial interface is forced to a 9600, 8-N-1 rate.</p> <p>Sleep Interrupt – When taken Low, this pin wakes the radio from any of the three sleep modes.</p> <p>Note: <i>Pulling this pin to GND disables some modes of operation, therefore it should not be permanently pulled Low during normal operation.</i></p>
13	14	I	GIO_4	Generic Input
14	5	I	$\overline{\mu\text{P_Reset}}$	Reset – Controlled by the RM024 for power-on reset if left unconnected. After a stable power-on reset, a logic low pulse resets the transceiver.
15	11	I	$\overline{\text{CMD/Data}}$	When logic Low, the transceiver interprets incoming OEM host data as command data. When logic High, the transceiver interprets OEM host data as transmit data.
16	15	O	$\overline{\text{In Range}}$	When logic Low, the client is in range and synchronized with a server. This is always Low on a server.
17	16	I	$\overline{\text{RTS}}$	<p>Request to Send – Floats high if left unconnected. When enabled in EEPROM, the module will not transmit Serial UART data to the OEM Host unless this pin is Low.</p>
18	12	O	$\overline{\text{CTS}}$	<p>Clear to Send – CTS is used for hardware flow control indication to the OEM Host. CTS toggles high when the Serial UART RX input buffer reaches the CTS On threshold and remains high until the buffer recedes below the CTS Off threshold.</p>
19	18		GIO_8	Generic Input
20	13		GIO_5	Reserved for future use. Do not connect.
21	4		GIO_6	Reserved for future use. Do not connect.
22	20	I	GIO_7	Analog to Digital input

Tips:

- All I/O directions are referenced to Vcc.
- All inputs are weakly pulled High via a 20 k Ohm pull-up resistor and may be left floating during normal operation.
- Minimum connections: VCC, VPA, GND, TXD, and RXD.
- Signal direction is with respect to the transceiver.
- Leave unused pins disconnected.

1.4 Input Characteristics

Table 3: Input characteristics

Signal Name	High Min.	High Max.	Low Min.	Low Max.
$\overline{\mu P_Reset}$	0.8 v	Vcc	0 v	0.6 v
RTS	2.31 v	Vcc	0 v	.99 v
AD_In	N/A	Vcc	0 v	N/A
All other inputs	70% Vcc	Vcc	0 v	30% Vcc

1.5 Output Characteristics

Table 4: Output characteristics

Signal Name	High Min.	High Max.	Low Min.	Low Max.	Sink Current
GO_0	2.5 v	3.3 v	0 v	0.4 v	20 mA
GO_1	2.5 v	3.3 v	0 v	0.4 v	20 mA
PWM_Output	N/A	3.3 v	0 v	N/A	4 mA
All other outputs	2.5 v	3.3 v	0 v	0.4 v	4 mA

1.6 Block Diagram

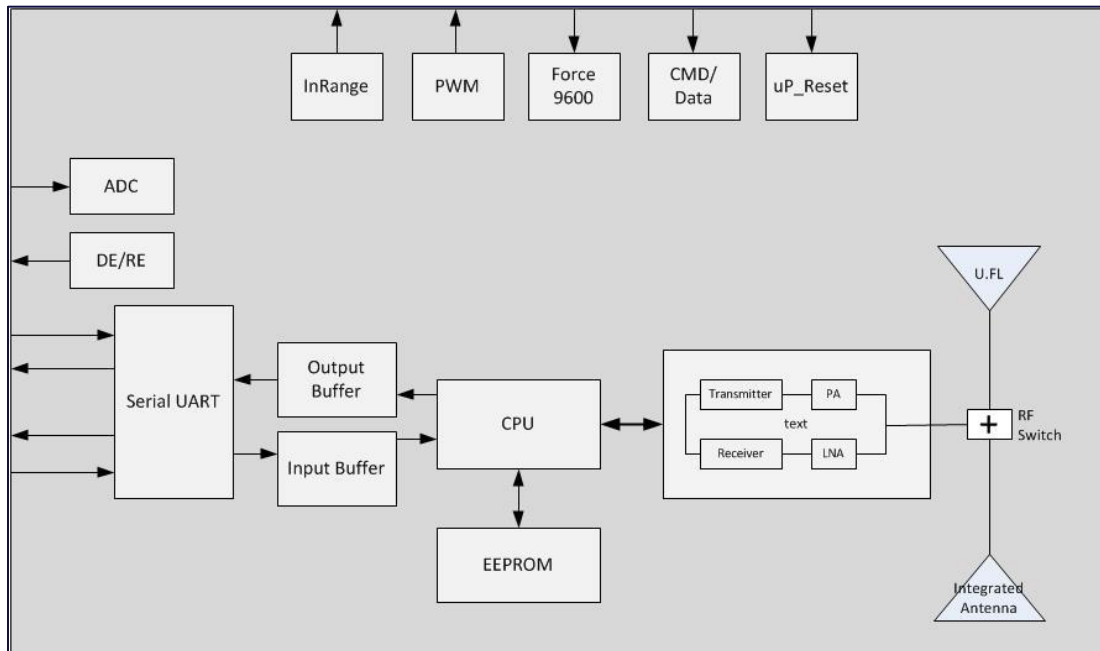

Figure 1: RM024 block diagram

1.7 Timing Specifications

Table 5: Timing specifications

Parameter	Server/Client	Min.	Typ.	Max.	Notes
Power on to CTS Low		5 ms	10 ms	N/A	The first boot after a FW upgrade requires more than the typical amount of time for CTS to toggle Low.
EEPROM Read		800 μ s	1 ms	2 ms	Measured from last byte of command to first byte of response: 870 μ s for 1 byte; 1.1 ms for 80 bytes; 1.4 ms for 256 bytes
EEPROM Write		20 ms	30 ms	40 ms	Measured. EEPROM writes cause the radio to resynchronize.
Power on to In Range	Client only	13 ms	600 ms	1700 ms	Maximum time assuming all beacons are heard; RF interference could extend the maximum time indefinitely.
Hop Period In Range			13.19 ms		
Hop Period Out of Range	Client only		38.4 ms		
Reset Pulse		250 ms			
PWM Output Period			39.3846 μ s		
Restore Default EEPROM Command		10 ms	38 ms		Restore command also initiates a soft reset, so monitoring CTS is the best indication of a completed command.
Non-specific AT Command		1 ms	10 ms		Some AT Commands could wait indefinitely for a response.
Write Flash					For FW upgrade.
Read Flash					

1.8 RF Hop Frame

The RM024 hops every 13.19 milliseconds and can be configured for two different RF data rates to provide options for range or throughput. During each hop, the RM024 reserves a certain amount of time for overhead such as the synchronization beacon, internal messaging, and user data transmission. The diagrams below outline the various transmissions that occur during a hop. These transmissions are transparent to the user sending data, but may be useful for applications that require critical timing. User data is only transmitted during the data slots and after the Interface Timeout or RF Packet Size criteria has been met. Data transmission only begins at the beginning of a data slot. When configured for Full Duplex, data slot 1 is reserved for the server and data slot 2 is shared by all clients for transmissions.

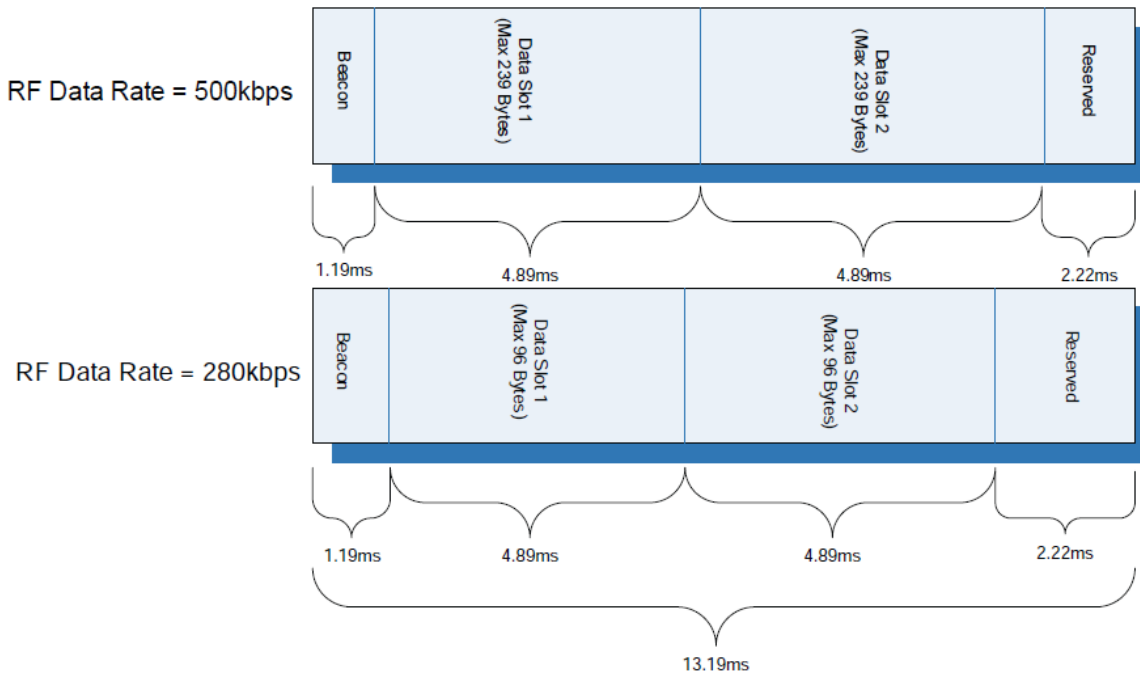

Figure 2: RF hop frame diagram

2 HARDWARE INTERFACE

2.1 Pin Descriptions

2.1.1 RXD and TXD

The RM024 accepts 3.3 VDC TTL level asynchronous serial data from the OEM host via the RXD pin. Data is sent from the transceiver, at 3.3 volt levels, to the OEM host via the TXD pin. Pins should be left floating or high when not in use. Leaving the RXD tied low results in the radio transmitting garbage serial data across the RF.

2.1.2 Force 9600 /Sleep Interrupt

When pulled logic Low before applying power or resetting, the transceiver’s serial interface is forced to 9600, 8-N-1 (8 data bits, no parity, 1 stop bit) regardless of the actual EEPROM setting. RTS is ignored, the interface timeout is also set to three milliseconds, and the RF packet size is set to the default size for the selected RF data rate. To exit, the transceiver must be reset or power-cycled with the test pin logic High or disconnected. When in Force 9600 mode, the radio’s receiver is disabled.

When enabled in the EEPROM, the 9600 Boot option causes the 9600 pin to be ignored on cold boot (power-up), command boot (0xCC 0xFF), and brown-out conditions. Therefore, the 9600 pin is only observed on warm boots (reset pin toggled). This can be helpful so that brown-out conditions don’t cause the baud rate to change if the 9600 pin happens to be low at the time. When 9600 Boot option is disabled, the 9600 pin is used for all boot conditions. 9600 Boot option is enabled by default.

Force 9600 is also used to wake the radio from sleep. When the pin is taken low, the radio wakes. The transceiver does not sleep if the pin is low when the sleep command is issued.

Note: Because this pin disables some modes of operation, it should not be permanently pulled Low during normal operation.

2.1.3 $\overline{\mu P_RESET}$

μP_Reset provides a direct connection to the reset pin on the RM024 microprocessor and is used to force a hard reset. For a valid reset, reset must be asserted Low for an absolute minimum of 250 nanoseconds (ns).

2.1.4 $\overline{Command/Data}$

When logic High, the transceiver interprets incoming serial data as transmit data to be sent to other transceivers. When logic Low, the transceiver interprets incoming serial data as command data. When logic Low, data packets from the radio are not transmitted over the RF interface, however, incoming packets from other radios are still received. Enabling CMD/Data RX Disable in the EEPROM causes incoming RF packets to be queued by the receiving radio while CMD/Data is low. When CMD/Data goes high, the data is sent over the serial interface.

2.1.5 $\overline{In_Range}$

The In_Range pin is driven low when a client radio's frequency hopping is synchronized with that of a server. In_Range is always driven low on a server. Following boot, In_Range transitions low in approximately 12 milliseconds on a server. For a client, the In_Range takes an average of 500 milliseconds; this time is dependent on the signal strength of the received beacon, the presence and strength of interference, and randomness of the sync function. It can vary from 150 milliseconds to over 1500 milliseconds.

2.1.6 $\overline{GO_0/Hop_Frame}$

The Hop Frame indicator functionality is disabled by default and controlled by the Control 1, Bit-6 EEPROM setting. When enabled, this pin transitions logic Low at the start of a hop and transitions logic High at the completion of a hop. The OEM host is not required to monitor hop frame.

2.1.7 \overline{RTS} and Handshaking

With RTS mode disabled, the transceiver sends any received data to the OEM host as soon as it is received. However, some OEM hosts are not able to accept data from the transceiver at all times. With RTS enabled in EEPROM, the OEM host can prevent the transceiver from sending data by de-asserting RTS (High). Once RTS is re-asserted (Low), the transceiver sends packets to the OEM host as they are received.

Note: Leaving RTS de-asserted for too long can cause data loss once the transceiver's transmit buffer reaches capacity.

2.1.8 \overline{CTS} Handshaking

If the transceiver buffer fills up and more bytes are sent to it before the buffer can be emptied, data loss occurs. The transceiver prevents this loss by de-asserting CTS high as the buffer fills up and asserting CTS low as the buffer is emptied. CTS should be monitored by the host device and data flow to the radio should be stopped when CTS is high.

2.1.9 $\overline{DE/RE}$

When enabled, RS485 Data Enable uses the DE/RE pin to control the DE pin on external RS-485 circuitry. When the transceiver has data to send to the host, it asserts DE/RE High, sends the data to the host, and then takes DE/RE low.

2.1.10 PWM Output

PWM output can be configured to output on any of three pins (SMT Pins 5, 6, or 7). The PWM Output can optionally produce a pulse width modulation for RSSI with a period of 39.3846 μS .

3 MECHANICAL CONSIDERATIONS

3.1 Mechanical Drawing

The pluggable versions of the RM024 consist of the surface mount RM024 on a pluggable adapter board. RM024 –C versions, which only feature an U.FL connector and no integrated antenna, are the same dimensions as in the mechanical drawings below (Figure 3 and Figure 4) with the stub for the antenna connector removed. For the surface mount units, this means the module is 32.38 mm long. For the pluggable units, the module is 33.02 mm long.

Note on Mechanical Drawings:

- All dimensions are in millimeters
- PC board material is 0.79 mm thick FR4
- Provide clearance of at least 1.5 mm around the module to be free of other components and features
- Module should not exceed 260°C during reflow soldering

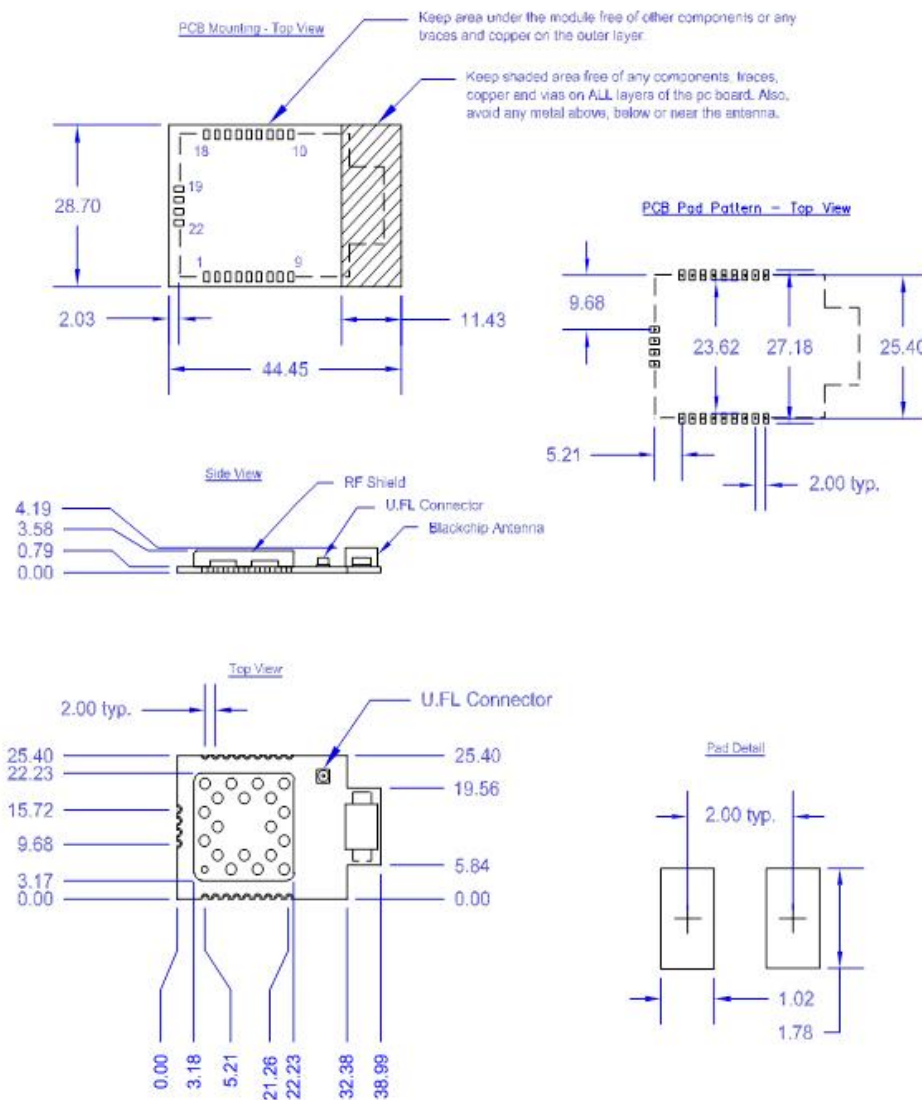

Figure 3: RM024 mechanical drawings

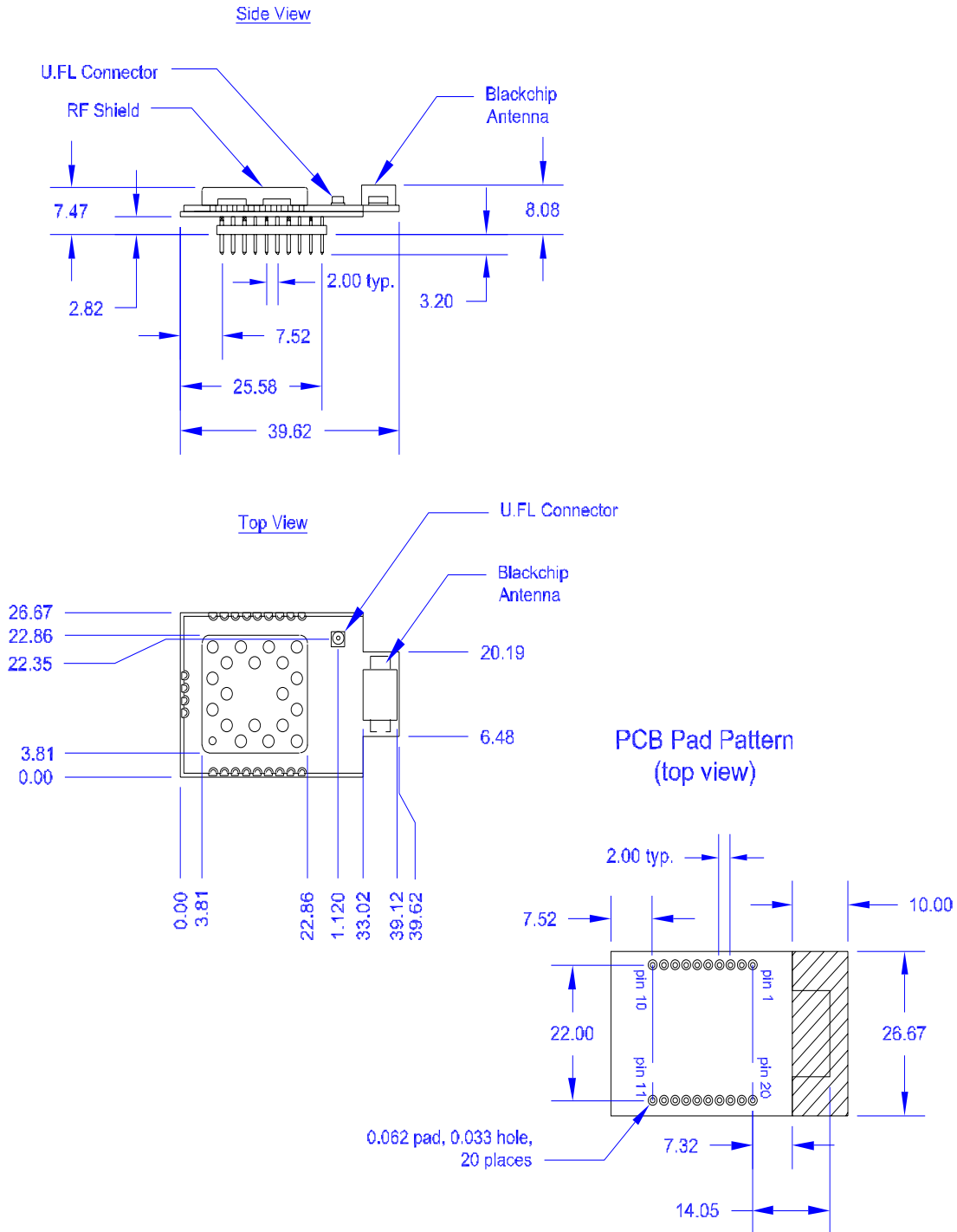

Figure 4: RM024 mechanical drawings

The pluggable RM024 uses a single row header with two mil spacing. The Mill Max 831-43-010-10-001000 is used on the RM024 development kit as a mating connector.



CAUTION

Level

This bag contains
MOISTURE-SENSITIVE DEVICES

3

1. Shelf life in sealed bag: 24 months at < 40°C and < 90% relative humidity.
2. Peak package body temperature: 245°C.
3. After this bag is opened, devices that will be subjected to reflow solder or another high temperature process must be:
 - a) Mounted within 168 hours at factory conditions of $\leq 30^{\circ}\text{C}$ @ 60% RH... or...
 - b) Stored at < 10% RH
4. Devices require bake, before mounting, if;
 - a) Humidity indicator card is >10% when read at $23 \pm 5^{\circ}\text{C}$...or...
 - b) 3a or 3b is not met.
5. If baking is required, devices may be baked for 48 hrs. at $125 \pm 5^{\circ}\text{C}$
Note: If device containers cannot be subjected to high temperature or shorter bake times are desired, reference IPC/JEDEC J-STD-033 for bake procedure.

Bag Seal Date

Figure 5: Moisture Content Warning

4 REFLOW PARAMETERS

Laird Connectivity’s surface mount modules are designed to be easily manufactured, including reflow soldering to a PCB. Ultimately, it is the responsibility of the customer to choose the appropriate solder paste and to ensure oven temperatures during reflow meet the requirements of the solder paste. Laird Connectivity’s surface-mount modules conform to J-STD-020D1 standards for reflow temperatures.

IMPORTANT: During reflow, modules should not be above 260°C and not for more than 30 seconds.

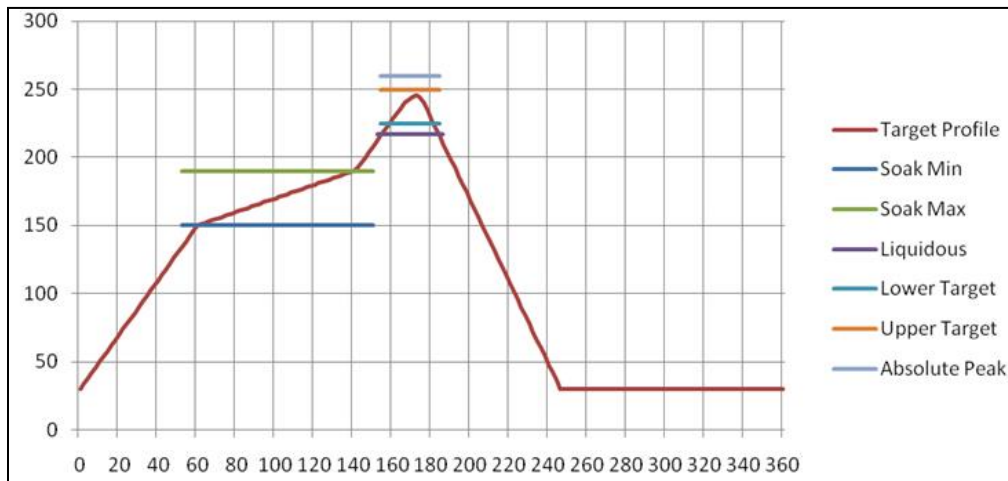

Figure 6: Recommended reflow temperature

Temperatures should not exceed the minimums or maximums presented in Figure 6.

Table 6: Reflow temperatures

Specification	Value	Unit
Temperature increase/decrease rate (maximum)	3	°C/Second
Temperature decrease rate (goal)	2-3	°C/Second
Soak temperature increase rate (goal)	.5-1	°C/Second
Flux soak period (minimum)	60	Seconds
Flux soak period (maximum)	90	Seconds
Flux soak temperature (minimum)	150	°C
Flux soak temperature (maximum)	190	°C
Time above liquidus (maximum)	60	Seconds
Time above liquidus (minimum)	20	Seconds
Time in target reflow range (goal)	30	Seconds
Time at absolute peak (maximum)	30	Seconds
Liquidus temperature (SAC305)	217	°C
Lower target reflow temperature	225	°C
Upper target reflow temperature	250	°C
Absolute peak temperature	260	°C

5 ORDERING INFORMATION

5.1 Product Part Numbers

RM024 Part Number	Form Factor	Maximum Tx Power	Antenna	EERPOM Product ID
RM024-S125-C-30	SMT	125 mW	u.FL Jack	RM024125C30
RM024-P125-C-30	Pluggable	125 mW	u.FL Jack	RM024125C30
RM024-S10-C-30	SMT	10 mW (CE)	u.FL Jack	RM02410C30
RM024-P10-C-30	Pluggable	10 mW (CE)	u.FL Jack	RM02410C30

Developer Kit Part Number	Description
DVK-RM024-CE	RM024 Developer Kit, Pluggable, 3.3V TTL Serial, 10 mW, Multiple Antennas, CE Approved
DVK-RM024-FCC	RM024 Developer Kit, Pluggable, 3.3V TTL Serial, 125mW, Multiple Antenna

6 REGULATORY INFORMATION

Note: For complete regulatory information, refer to the [RM024 Regulatory Information](#) document which is also available from the [RM024 product page](#).

The RM024 holds current certifications in the following countries:

Country/Region	Regulatory ID
USA (FCC)	KQL-RM024
EU	N/A
Canada (ISED)	2268C-RM024
Japan (MIC)	RM024-S10-M: 204-320033 RM024-P10-M: 204-320034 RM024-P10-C: 204-820089
Taiwan (NCC)	N/A
Korea (KC)	RM024-S10-C/RM024-S10-M: R-C-LAI-RM024-S10-C
Australia	N/A
New Zealand	N/A
Russia	N/A

7 RELATED DOCUMENTS AND FILES

Additional RM024 technical documents and software downloads are available from the [Laird Connectivity RM024 product page](#) under the Documentation tab and Software Downloads tabs.

8 ADDITIONAL ASSISTANCE

Please contact your local sales representative or our support team for further assistance:

Laird Connectivity
Support Centre: <https://www.lairdconnect.com/resources/support>
Email: wireless.support@lairdconnectivity.com
Phone: Americas: +1-800-492-2320
Europe: +44-1628-858-940
Hong Kong: +852 2923 0610
Web: <https://www.lairdconnect.com/products>

Note: Information contained in this document is subject to change.

Copyright 2020 Laird Connectivity. All Rights Reserved. Patent pending. Any information furnished by Laird Connectivity and its agents is believed to be accurate and reliable. All specifications are subject to change without notice. Responsibility for the use and application of Laird Connectivity materials or products rests with the end user since Laird Connectivity and its agents cannot be aware of all potential uses. Laird Connectivity makes no warranties as to non-infringement nor as to the fitness, merchantability, or sustainability of any Laird Connectivity materials or products for any specific or general uses. Laird Connectivity or any of its affiliates or agents shall not be liable for incidental or consequential damages of any kind. All Laird Connectivity products are sold pursuant to the Laird Connectivity Terms and Conditions of Sale in effect from time to time, a copy of which will be furnished upon request. Nothing herein provides a license under any Laird Connectivity or any third-party intellectual property right.